

LOC		DIST		P		ZONE		LTR		REVISIONS		DATE	APPD
AD	25									DESCRIPTION			
										E	REVISED PER 0512-0091-03	22JUL03	WM

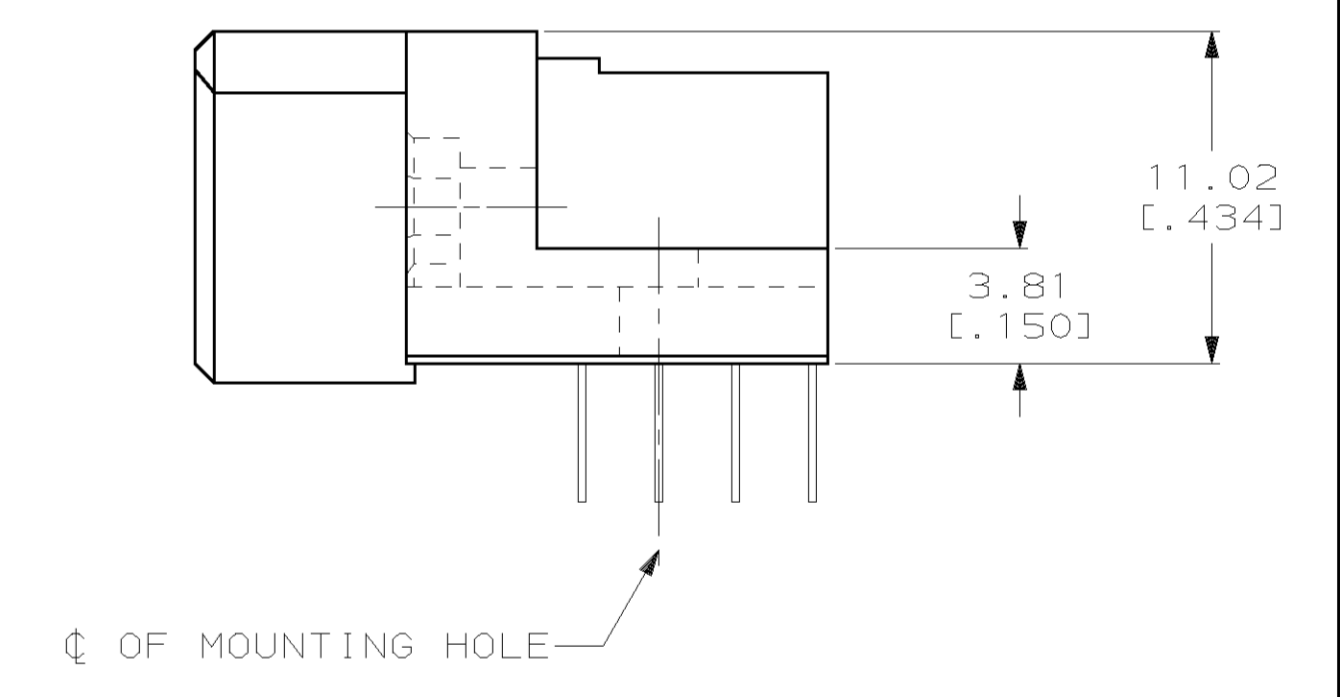

DO NOT SCALE PRINT. UNLESS SPECIFIED DIMENSIONS IN mm [INCHES]		TOLERANCES UNLESS SPECIFIED		NAME		CAGE CODE		DRAWING NO	
TOLERANCES UNLESS SPECIFIED		2 PLC DEC ± .13 [.005]		HDI, 4 ROW, RECEPTACLE ASSEMBLY, 4.57 [.180] LONG SOLDER TAILS, .00076 [.00030] GOLD PLATE SELECT LOADED		00779		532912	
3 PLC DEC ± .13 [.005]		ANGLES ± -		AMP Incorporated Harrisburg, PA 17105-3608		SCALE 4:1		SHEET 1 OF 2	
MATERIAL		FINISH		PRODUCT SPEC		APPLICATION SPEC		WEIGHT	
1 2		3		-		-		-	

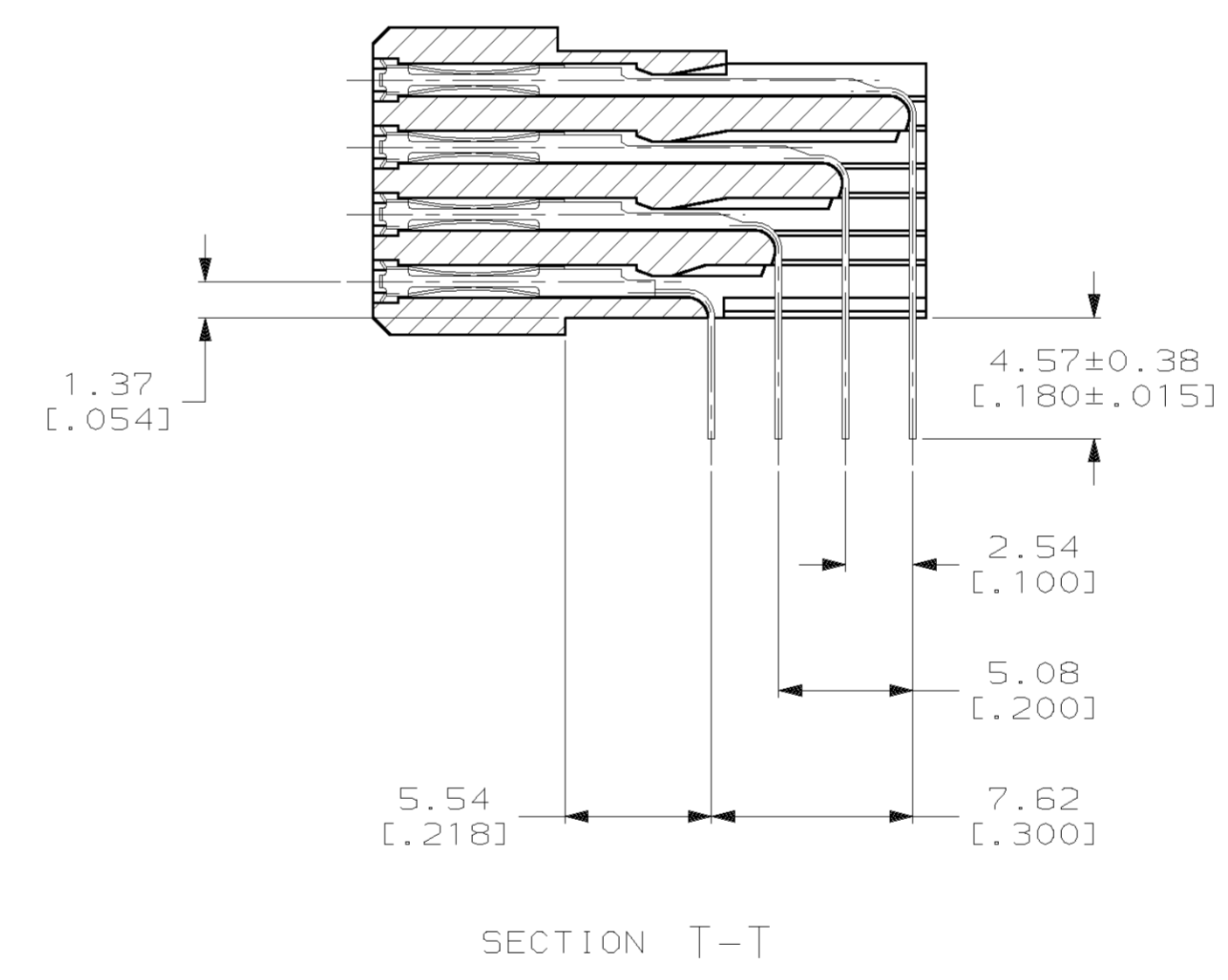
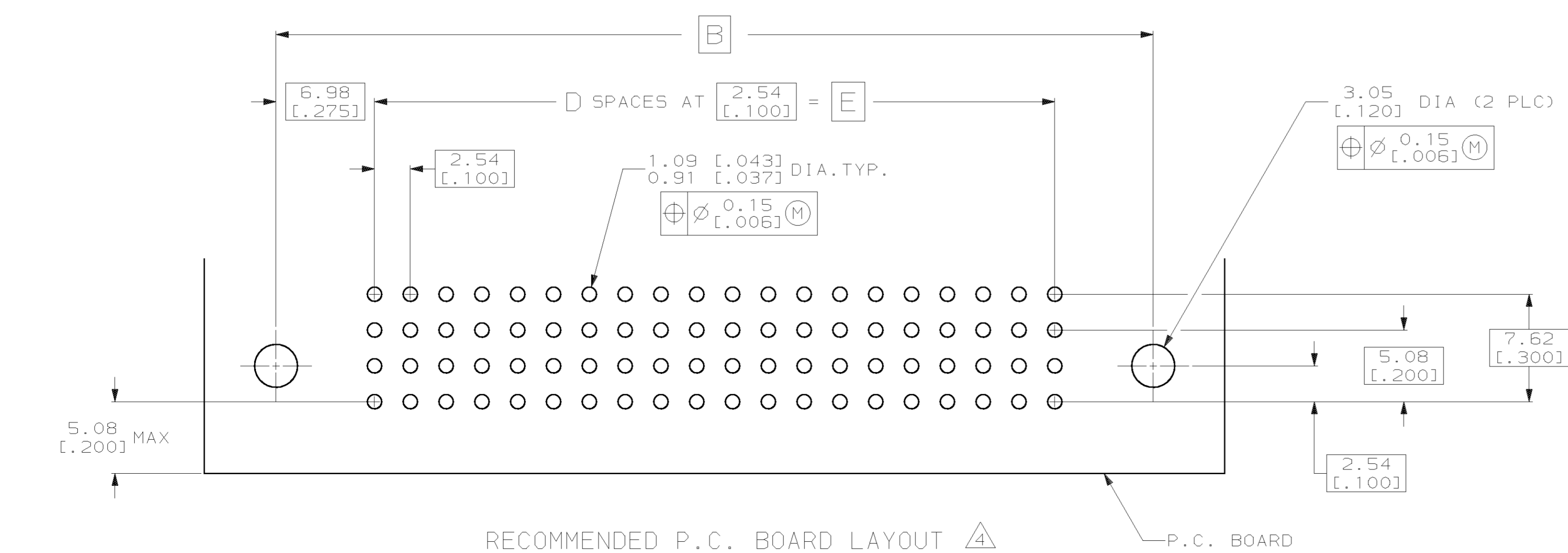
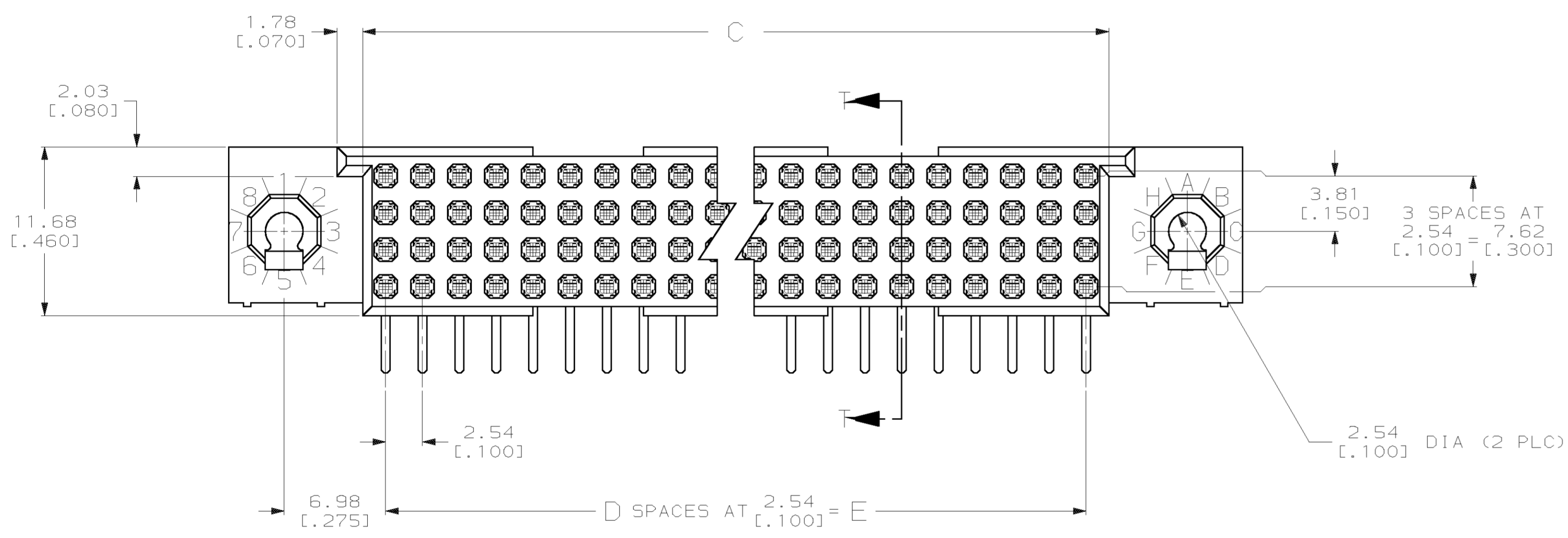
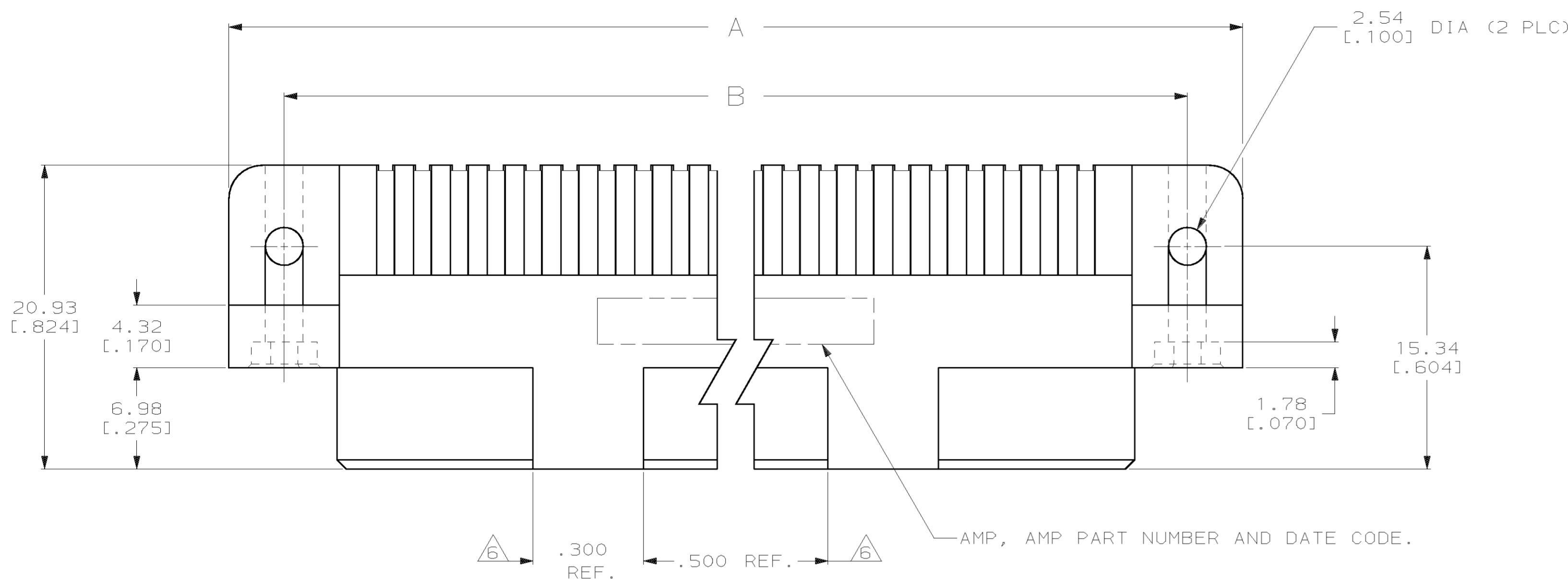

LOC		DIST		P		F		ZONE		LTR		REVISIONS			
AD	25											DESCRIPTION	DATE	APPD	
												E	SEE SHEET 1	-	-

- 1 HOUSING MATERIAL: THERMOPLASTIC, COLOR: NATURAL.
- 2 CONTACT MATERIAL: COPPER ALLOY.
- 3 CONTACT FINISH: .00127-.00254 [.000050-.000100] NICKEL UNDERPLATE ALL OVER, .000076 [.000030] GOLD PLATE IN CONTACT AREA, TIN-LEAD PLATED SOLDER TAILS.
- 4 SOLDER TAILS MUST FIT HOLE PATTERN AS SHOWN ON THE RECOMMENDED P.C. BOARD LAYOUT.
- 5. DIMENSIONS IN BRACKETS ARE IN INCHES.
- 6. QUANTITIES OF VOID CORING ARE DEPENDENT ON THE POSITION SIZE OF THE HOUSING.

NUMBER	1	5	10	15	20	25	30	35	40	45	50	55	60	65	70	71	LETTER	END	532912-1
END	X	X	X	X	X	X	X	X	X	X	X	X	X	X	X	X	X	X	
	X	X	X	X	X	X	X	X	X	X	X	X	X	X	X	X	X	X	
	X	X	X	X	X	X	X	X	X	X	X	X	X	X	X	X	X	X	

COLUMN NUMBER - CONTACT LOCATION TABLE

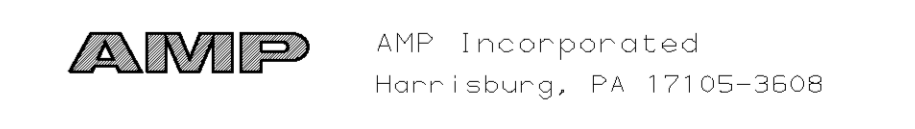
		177.80	70	180.95	191.77	199.39	284	532912-1
		[7.000]		[7.124]	[7.550]	[7.850]		
		E	D	C	B	A	POSN	PART NUMBER
DO NOT SCALE PRINT. UNLESS SPECIFIED DIMENSIONS IN mm [INCHES] TOLERANCES ON: 2 PLC DEC ± - 3 PLC DEC ± 0.13 [.005] ANGLES ± -	DR 6/14/90 R.K.SEIFRIED CHK 2/26/92 J.D.WEARY APPD 2/26/92 J.D.WEARY	 AMP Incorporated Harrisburg, PA 17105-3608						
MATERIAL 1 2	APPD 2/26/92 J.D.WEARY PRODUCT SPEC -	NAME HDI, 4 ROW, RECEPTACLE ASSEMBLY, 4.57 [.180] LONG SOLDER TAILS, .00076 [.000030] GOLD PLATE SELECT LOADED						
FINISH 3	APPD 2/26/92 J.D.WEARY APPLICATION SPEC -	SIZE D	CAGE CODE 00779	DRAWING NO 532912		SHEET 2 OF 2		
WEIGHT	-	SCALE	4:1					

